

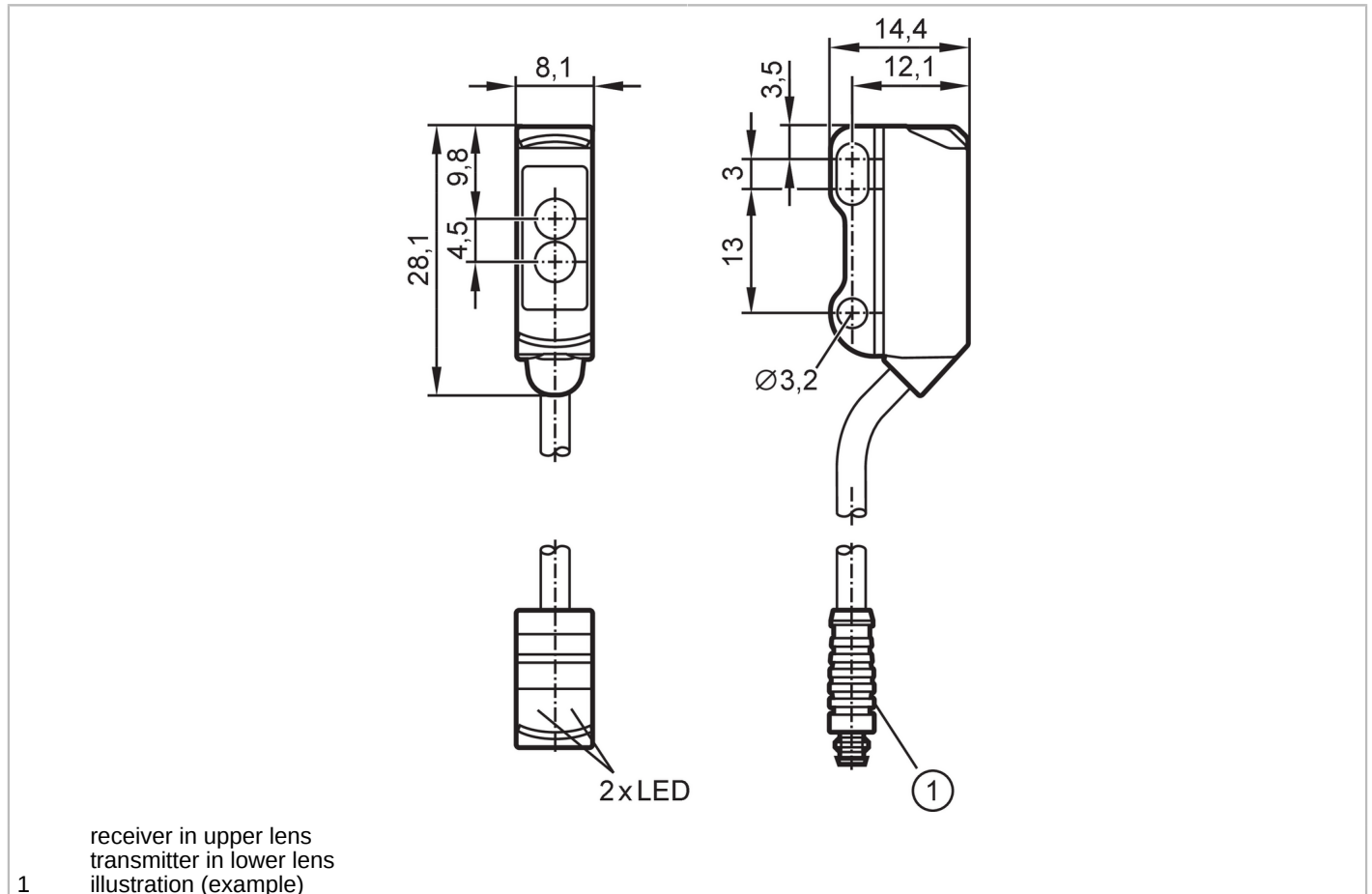

## Diffuse reflection sensor

O8T-FPKG/IO-Link/0,30M/AS/3P



### Product characteristics

Type of light	red light
Housing	rectangular

### Application

Function principle	Diffuse reflection sensor
Application	For applications in robotics, assembly and handling technology

### Electrical data

Operating voltage	[V]	10...30 DC
Current consumption	[mA]	20; ((24 V))
Protection class		III
Reverse polarity protection		yes
Type of light		red light
Wave length	[nm]	633

### Outputs

Electrical design		PNP
Output function		light-on/dark-on mode; (programmable)
Max. voltage drop switching output DC	[V]	2.5



## Diffuse reflection sensor

O8T-FPKG/IO-Link/0,30M/AS/3P

Permanent current rating of switching output DC	[mA]	100
Switching frequency DC	[Hz]	1000
Short-circuit protection		yes
Type of short-circuit protection		pulsed

## Detection zone

Range	[mm]	0...180; (white paper 200 x 200 mm)
Max. light spot diameter	[mm]	18
Light spot dimensions refer to		at maximum range

## Interfaces

Communication interface	IO-Link	
Transmission type	COM2 (38,4 kBaud)	
IO-Link revision	1.1	
SDCI standard	IEC 61131-9	
Profiles	Smart Sensor - SSP 0	Generic Profiled Sensor
	Function	Device identification
	Function	Multiple switching signal
	Function	Device diagnosis
	Function	Teach channel
SIO mode	yes	
Required master port type	A	
Min. process cycle time	[ms]	2.5
IO-Link process data (cyclical)	<b>function</b>	<b>bit length</b>
	process value	8
	device status	4
	binary switching information	1
IO-Link functions (acyclical)	application specific tag; operating hours counter; switching cycles counter	
Supported DeviceIDs	<b>Type of operation</b>	<b>DeviceID</b>
	default	788

## Operating conditions

Ambient temperature	[°C]	-25...60
Protection		IP 65; IP 67

## Tests / approvals

EMC	EN 60947-5-2	
MTTF	[years]	1067
UL approval	Ta	-25...60 °C
	Enclosure type	Type 1
	voltage supply	Limited Voltage/Current
	UL approval no.	E017
	File number UL	E174191

## Mechanical data

Weight	[g]	21.2
Housing		rectangular
Dimensions	[mm]	28.1 x 8.1 x 14.4
Materials		housing: ABS; rear of the housing: stainless steel (316L/1.4404)

# O8T202



## Diffuse reflection sensor

O8T-FPKG/IO-Link/0,30M/AS/3P

Lens material	front pane:PMMA
Lens alignment	side lens

### Displays / operating elements

Display	switching status	1 x LED, yellow
	operation	1 x LED, green

### Remarks

Pack quantity	1 pcs.
---------------	--------

### Electrical connection

Cable: 0.3 m, PVC, black,  $\varnothing$  2.9 mm; 3 x 0.08 mm<sup>2</sup>

Connector: 1 x M8; coding: A; Contacts: 3

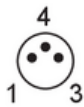

### Connection

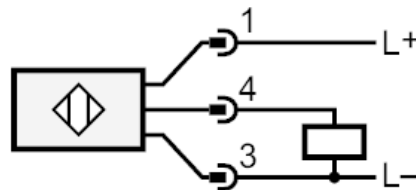

### Diagrams and graphs

excess gain graph

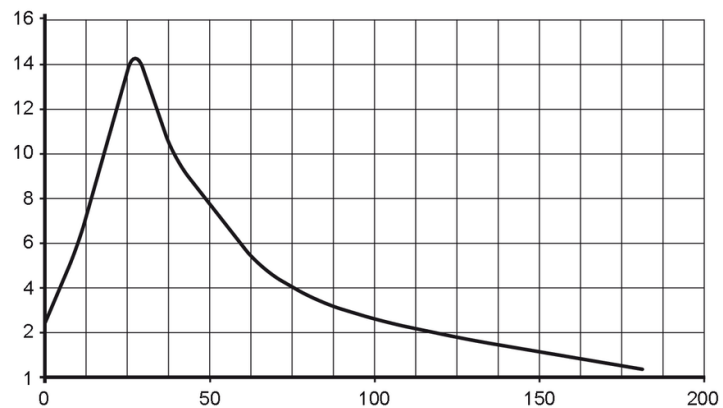

x: distance [mm]  
y: excess gain factor