

OG5123

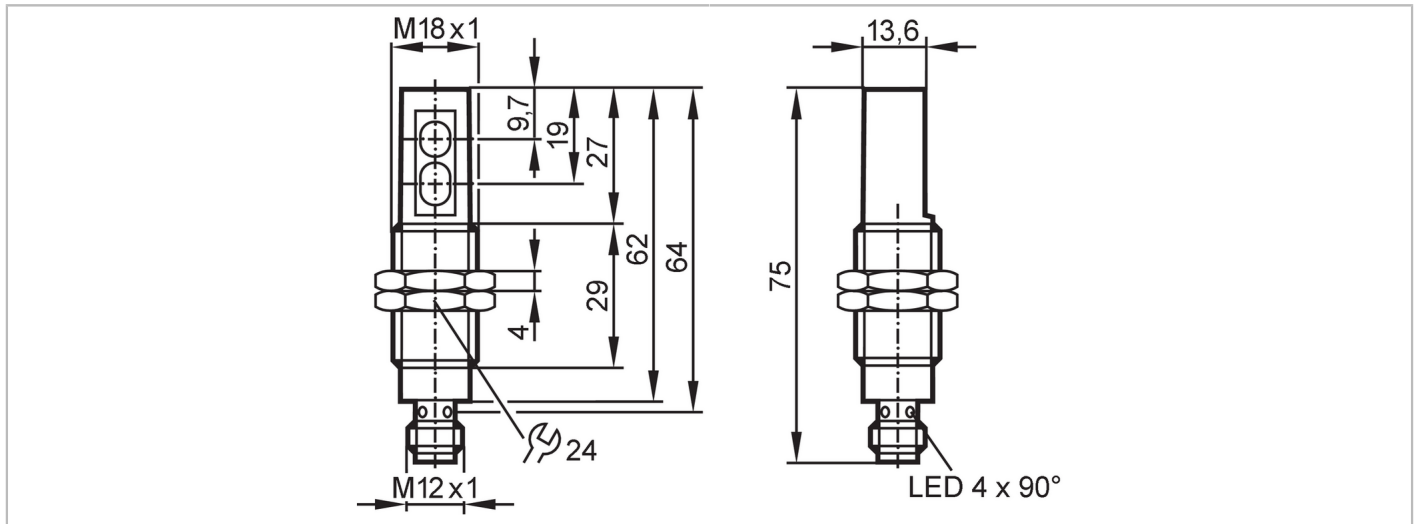

Diffuse reflection sensor with background suppression

OGH-HPKG/US/90°/100MM



Product characteristics		
Type of light		red light
Housing		threaded type
Application		
Special feature		Background suppression
Function principle		Diffuse reflection sensor
Application		Industrial applications / factory automation
Electrical data		
Operating voltage	[V]	10...30 DC; ("supply class 2" to cULus)
Current consumption	[mA]	25
Protection class		II
Reverse polarity protection		yes
Type of light		red light
Wave length	[nm]	625
Outputs		
Electrical design		PNP
Output function		light-on mode
Max. voltage drop switching output DC	[V]	2.5
Permanent current rating of switching output DC	[mA]	200
Switching frequency DC	[Hz]	1000
Short-circuit protection		yes
Type of short-circuit protection		pulsed
Overload protection		yes
Detection zone		
Range	[mm]	< 100; (white paper 200 x 200 mm 90% remission)
Range adjustable		no

OG5123



Diffuse reflection sensor with background suppression

OGH-HPKG/US/90°/100MM

Max. light spot diameter [mm]	16
Light spot dimensions refer to	at maximum range
Background suppression available	yes

Operating conditions

Ambient temperature [°C]	-25...60
Protection	IP 68

Tests / approvals

EMC	EN 60947-5-2	
	EN 55011	class B
MTTF [years]	541	

Mechanical data

Weight [g]	57.3
Housing	threaded type
Dimensions [mm]	M18 x 1 / L = 65
Thread designation	M18 x 1
Materials	housing: stainless steel; cover: ABS
Lens material	front pane:PMMA

Displays / operating elements

Display	switching status	1 x LED, yellow
	operation	1 x LED, green

Accessories

Items supplied	Nuts: 2 lock washers: 2
----------------	----------------------------

Remarks

Pack quantity	1 pcs.
---------------	--------

Electrical connection

Connector: 1 x M12; coding: A; Contacts: 4



Connection

