

OG5124

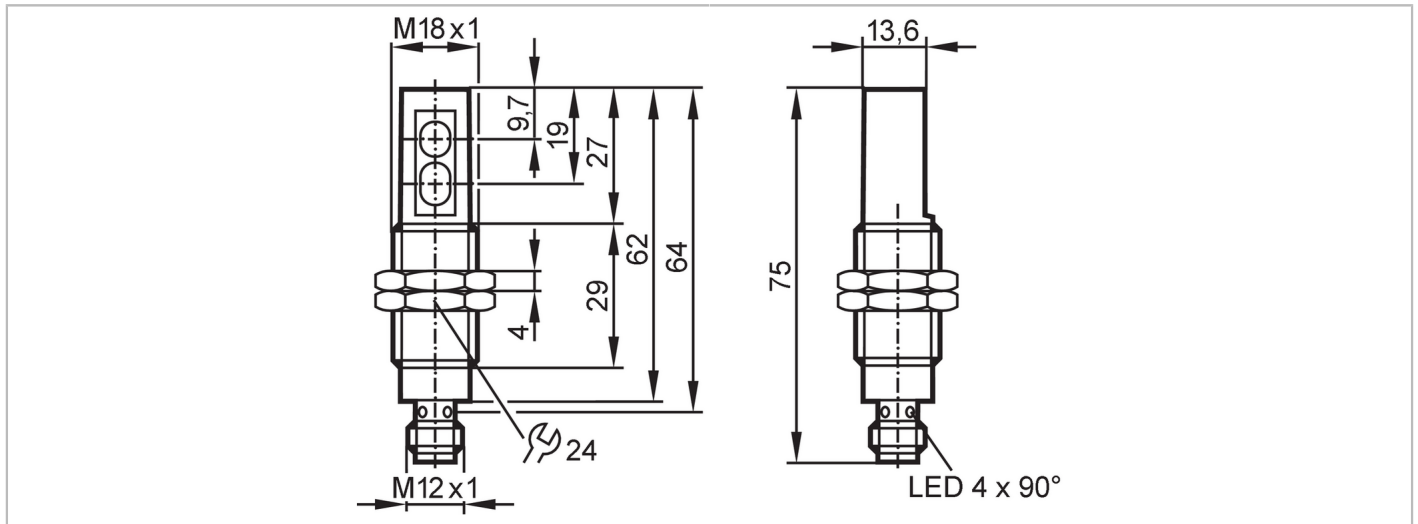

Diffuse reflection sensor with background suppression

OGH-HPKG/US/90°/200MM



Product characteristics	
Type of light	red light
Housing	threaded type
Application	
Special feature	Background suppression
Function principle	Diffuse reflection sensor
Application	Industrial applications / factory automation
Electrical data	
Operating voltage [V]	10...30 DC; ("supply class 2" to cULus)
Current consumption [mA]	25
Protection class	II
Reverse polarity protection	yes
Type of light	red light
Wave length [nm]	625
Outputs	
Electrical design	PNP
Output function	light-on mode
Max. voltage drop switching output DC [V]	2.5
Permanent current rating of switching output DC [mA]	200
Switching frequency DC [Hz]	1000
Short-circuit protection	yes
Type of short-circuit protection	pulsed
Overload protection	yes
Detection zone	
Range [mm]	< 200; (white paper 200 x 200 mm 90% remission)
Range adjustable	no

OG5124



Diffuse reflection sensor with background suppression

OGH-HPKG/US/90°/200MM

Max. light spot diameter [mm]	28
Light spot dimensions refer to	at maximum range
Background suppression available	yes

Operating conditions

Ambient temperature [°C]	-25...60
Protection	IP 68

Tests / approvals

EMC	EN 60947-5-2	
	EN 55011	class B
MTTF [years]	541	

Mechanical data

Weight [g]	57.5
Housing	threaded type
Dimensions [mm]	M18 x 1 / L = 65
Thread designation	M18 x 1
Materials	housing: stainless steel; cover: ABS
Lens material	front pane:PMMA

Displays / operating elements

Display	switching status	1 x LED, yellow
	operation	1 x LED, green

Accessories

Items supplied	Nuts: 2 lock washers: 2
----------------	----------------------------

Remarks

Pack quantity	1 pcs.
---------------	--------

Electrical connection

Connector: 1 x M12; coding: A; Contacts: 4



Connection

