

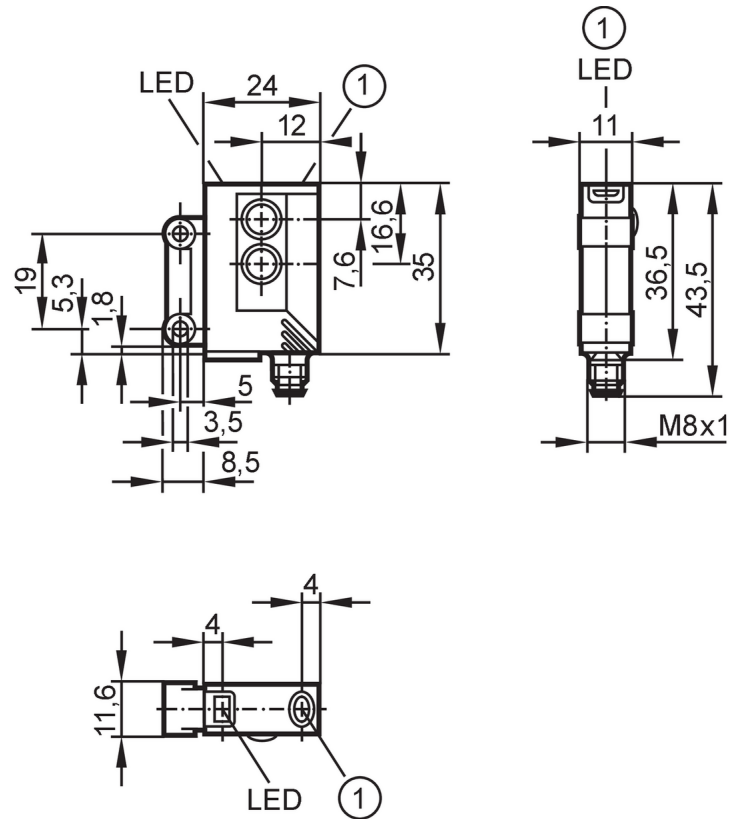

## Diffuse reflection sensor

OJB-FPKG/FO/AS



1 pushbutton



### Product characteristics

Type of light	red light
Housing	rectangular

### Application

Function principle	Diffuse reflection sensor
Application	Industrial applications / factory automation

### Electrical data

Operating voltage	[V]	10...30 DC
Current consumption	[mA]	< 22
Protection class		III
Reverse polarity protection		yes
Type of light		red light
Wave length	[nm]	660

### Outputs

Electrical design		PNP
Output function		light-on/dark-on mode; (programmable)
Max. voltage drop switching output DC	[V]	2.5
Permanent current rating of switching output DC	[mA]	200
Switching frequency DC	[Hz]	2000

# OJ5100



## Diffuse reflection sensor

OJB-FPKG/FO/AS

Short-circuit protection	yes
Type of short-circuit protection	pulsed
Overload protection	yes

### Detection zone

Range [mm]	1...600; (white paper 200 x 200 mm 90% remission)
Range adjustable	yes
Max. light spot diameter [mm]	60
Light spot dimensions refer to	at maximum range

### Operating conditions

Ambient temperature [°C]	-25...60
Protection	IP 67

### Tests / approvals

EMC	EN 60947-5-2
MTTF [years]	867

### Mechanical data

Weight [g]	39.6
Housing	rectangular
Dimensions [mm]	35 x 24 x 11
Materials	housing: ABS; LED window: SEPS; pushbutton: SEPS
Lens material	front pane:glass
Lens alignment	front lens

### Displays / operating elements

Display	switching status	1 x LED, yellow
	operation	1 x LED, green
	function	1 x LED, red
Electronic lock	yes	

### Accessories

Items supplied	screws: 2
	spring washers: 2
	Nuts: 2

### Remarks

Remarks	operating voltage "supply class 2" according to cULus
Pack quantity	1 pcs.

### Electrical connection

Connector: 1 x M8; coding: A; Contacts: 4



# OJ5100



## Diffuse reflection sensor

OJB-FPKG/FO/AS

### Connection

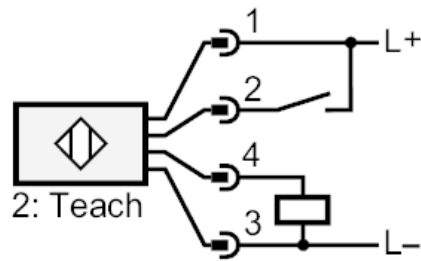

2 Teach

### Diagrams and graphs

excess gain graph

