

# PE2094

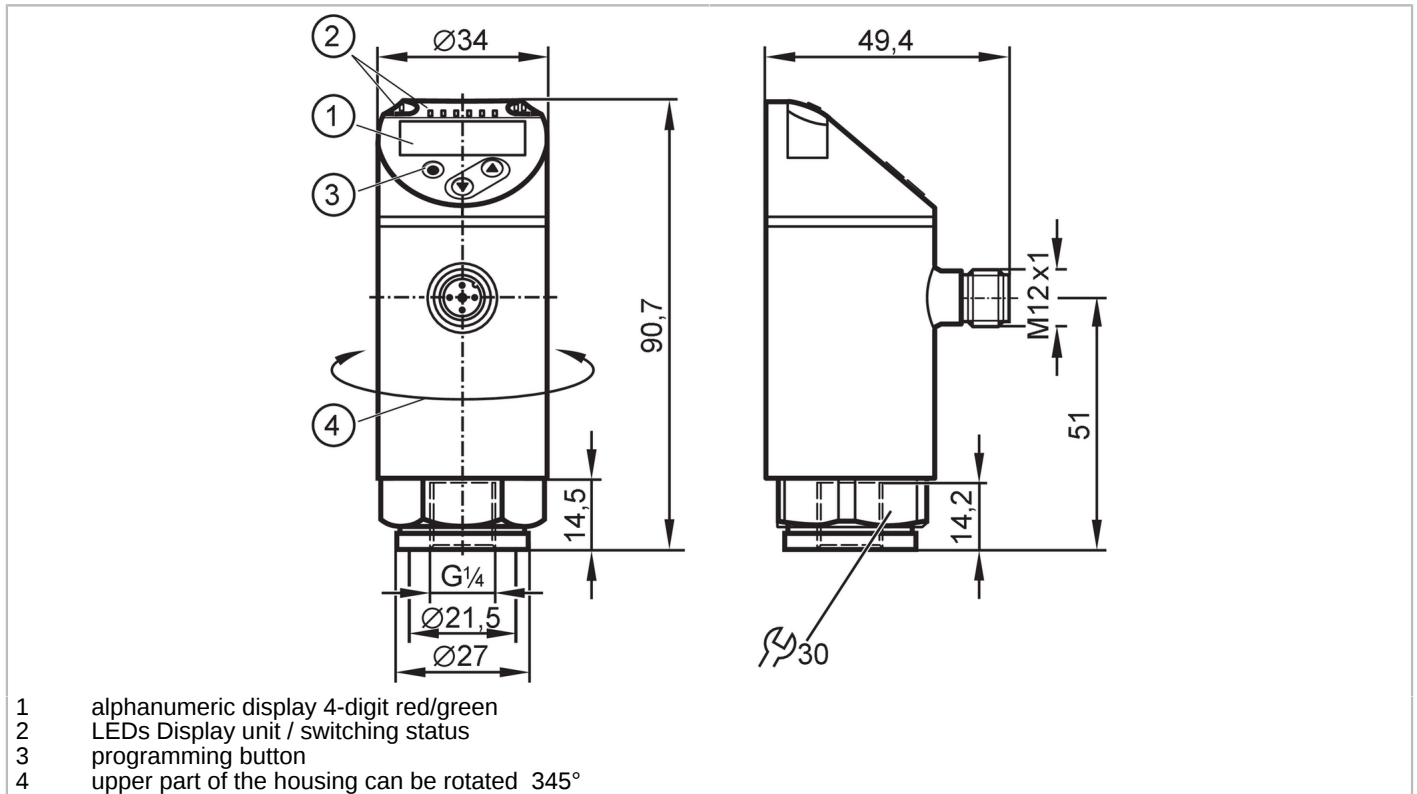

## Pressure sensor with display

PE-010-RER14-MFRKG/US/ /E



Product characteristics			
Number of inputs and outputs	Number of digital outputs: 2; Number of analogue outputs: 1		
Measuring range	-1...10 bar	-14.6...145 psi	-0.1...1 MPa
Process connection	threaded connection G 1/4 internal thread		
Application			
Special feature	Gold-plated contacts		
Measuring element	ceramic-capacitive pressure measuring cell		
Application	for industrial applications		
Media	liquids and gases		
Medium temperature [°C]	-25...80		
Min. burst pressure	150 bar	2175 psi	15 MPa
Pressure rating	75 bar	1087 psi	7.5 MPa
Vacuum resistance	-1000 mbar	-0.1 MPa	
Type of pressure	relative pressure		
Electrical data			
Operating voltage [V]	18...30 DC; (to SELV/PELV)		
Current consumption [mA]	< 35		
Min. insulation resistance [MΩ]	100; (500 V DC)		
Protection class	III		
Reverse polarity protection	yes		
Power-on delay time [s]	0.3		
Integrated watchdog	yes		



## Pressure sensor with display

PE-010-RER14-MFRKG/US/ /E

Inputs / outputs			
Number of inputs and outputs	Number of digital outputs: 2; Number of analogue outputs: 1		
Outputs			
Total number of outputs	2		
Output signal	switching signal; analogue signal; IO-Link; (configurable)		
Electrical design	PNP/NPN		
Number of digital outputs	2		
Output function	normally open / normally closed; (parameterisable)		
Max. voltage drop switching output DC [V]	2		
Permanent current rating of switching output DC [mA]	250		
Switching frequency DC [Hz]	< 500		
Number of analogue outputs	1		
Analogue current output [mA]	4...20; (scalable 1:5)		
Max. load [Ω]	500		
Analogue voltage output [V]	0...10; (scalable 1:5)		
Min. load resistance [Ω]	2000		
Short-circuit protection	yes		
Type of short-circuit protection	pulsed		
Overload protection	yes		
Measuring/setting range			
Measuring range	-1...10 bar	-14.6...145 psi	-0.1...1 MPa
Set point SP	-0.94...10 bar	-13.6...145 psi	-0.094...1 MPa
Reset point rP	-0.98...9.96 bar	-14.2...144.4 psi	-0.098...0.996 MPa
Analogue start point	-1...8 bar	-14.6...116 psi	-0.1...0.8 MPa
Analogue end point	1...10 bar	14.6...145 psi	0.1...1 MPa
In steps of	0.02 bar	0.2 psi	0.002 MPa
Accuracy / deviations			
Switch point accuracy [% of the span]	< ± 0,4; (Turn down 1:1)		
Repeatability [% of the span]	< ± 0,1; (with temperature fluctuations < 10 K; Turn down 1:1)		
Characteristics deviation [% of the span]	< ± 0,25 (BFSL) / < ± 0,5 (LS); (Turn down 1:1; BFSL = Best Fit Straight Line; LS = limit value setting)		
Hysteresis deviation [% of the span]	< ± 0,1; (Turn down 1:1)		
Long-term stability [% of the span]	< ± 0,05; (Turn down 1:1; per 6 months)		
Temperature coefficient zero point [% of the span / 10 K]	0,2; (-25...80 °C)		
Temperature coefficient span [% of the span / 10 K]	0,2; (-25...80 °C)		
Notes on the accuracy / deviation	switch point accuracy, linearity error under DNV GL: < ± 1%: < ± 1%		

# PE2094



## Pressure sensor with display

PE-010-RER14-MFRKG/US/ /E

Response times		
Response time	[ms]	< 1.5
Delay time programmable dS, dr	[s]	0...50
Damping process value dAP	[s]	0...4
Damping for the analogue output dAA	[s]	0...4
Max. response time analogue output	[ms]	3
Software / programming		
Parameter setting options	hysteresis / window; normally open / normally closed; switch-on/switch-off delay; Damping; Display unit; current/voltage output	
Interfaces		
Communication interface	IO-Link	
Transmission type	COM2 (38,4 kBaud)	
IO-Link revision	1.1	
SDCI standard	IEC 61131-9	
Profiles	Smart Sensor - SSP 0	Generic Profiled Sensor
	Function	Device identification
	Function	Process data variable
	Function	Device diagnosis
SIO mode	yes	
Required master port type	A	
Process data analogue	1	
Process data binary	2	
Min. process cycle time	[ms]	2.3
Supported DeviceIDs	<b>Type of operation</b>	<b>DeviceID</b>
	default	463
Operating conditions		
Ambient temperature	[°C]	-25...80
Storage temperature	[°C]	-40...100
Protection	IP 65; IP 67	
Tests / approvals		
EMC	DIN EN 61000-6-2	
	DIN EN 61000-6-3	
Shock resistance	DIN EN 60068-2-27	50 g (11 ms)
Vibration resistance	DIN EN 60068-2-6	20 g (10...2000 Hz)
MTTF	[years]	161
UL approval	UL approval no.	J012
Pressure Equipment Directive	Sound engineering practice; can be used for group 2 fluids; group 1 fluids on request	
Mechanical data		
Weight	[g]	236.5
Housing	cylindrical	
Dimensions	[mm]	Ø 34 / L = 90.7
Materials	stainless steel (316L/1.4404); PBT+PC-GF30; PBT-GF20; PC	
Materials (wetted parts)	stainless steel (316L/1.4404); Al2O3 (99.9%); ceramics); EPDM	

# PE2094



## Pressure sensor with display

PE-010-RER14-MFRKG/US/ /E

Min. pressure cycles	100 million
Tightening torque [Nm]	25...35; (recommended tightening torque; depends on the lubrication, the seal and the pressure load)
Process connection	threaded connection G 1/4 internal thread
Restrictor element integrated	no (can be retrofitted)

### Displays / operating elements

Display	Display unit	3 x LED, green (bar, psi, MPa)
	switching status	2 x LED, yellow
	measured values	alphanumeric display, red/green 4-digit

### Remarks

Pack quantity	1 pcs.
---------------	--------

### Electrical connection

Connector: 1 x M12; coding: A; Contacts: 4, gold-plated



### Connection

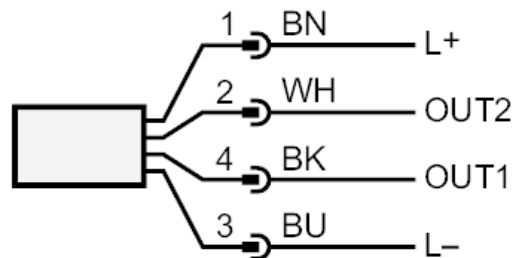

OUT1	switching output or IO-Link
OUT2	switching output or analogue output
	colours to DIN EN 60947-5-2
	Core colours :
BK =	black
BN =	brown
BU =	blue
WH =	white