

PF1507

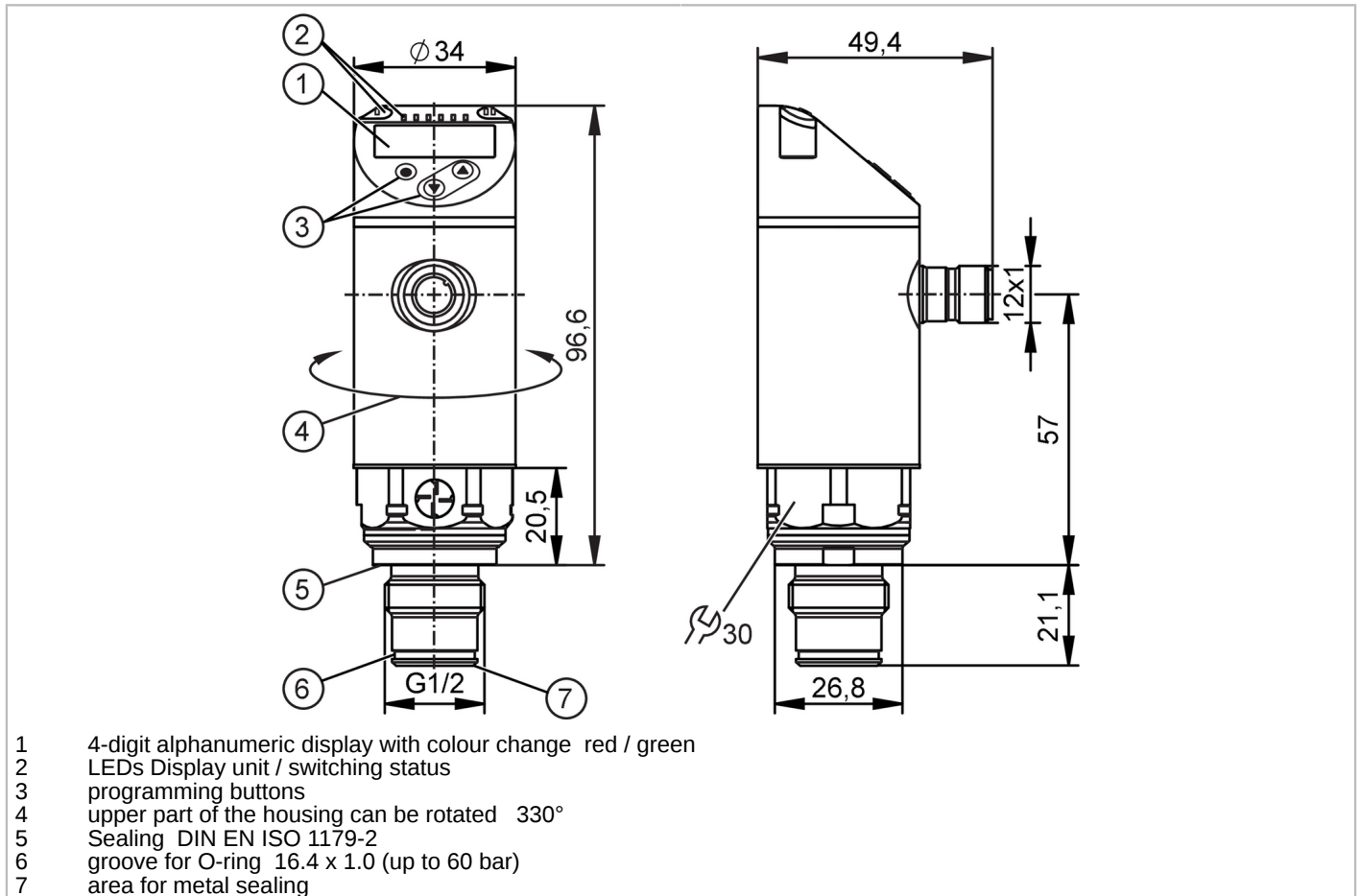

Pressure sensor with display

PF-001BREA12-MFRKG/US//P



- 1 4-digit alphanumeric display with colour change red / green
- 2 LEDs Display unit / switching status
- 3 programming buttons
- 4 upper part of the housing can be rotated 330°
- 5 Sealing DIN EN ISO 1179-2
- 6 groove for O-ring 16.4 x 1.0 (up to 60 bar)
- 7 area for metal sealing



Product characteristics

Number of inputs and outputs	Number of digital outputs: 2; Number of analogue outputs: 1	
Measuring range	-50...1000 mbar	-5...100 kPa
Process connection	threaded connection G 1/2 external thread - 21 mm	

Application

Special feature	Gold-plated contacts	
Measuring element	ceramic-capacitive pressure measuring cell	
Temperature monitoring	yes	
Application	flush mountable for industrial applications; for industrial applications	
Media	viscous media and liquids with suspended particles; Liquids; other media on request	
Medium temperature [°C]	-25...80; (flush mount zero-leak using metal-to-metal seal. for permissible temperatures of other sealing versions, see sealing materials under "Accessories")	
Min. burst pressure	40000 mbar	4000 kPa
Pressure rating	20000 mbar	2000 kPa
Vacuum resistance	-1000 mbar	-100 kPa
Type of pressure	relative pressure; vacuum	
No dead space	yes	

Electrical data

Operating voltage [V]	18...32 DC
-----------------------	------------

PF1507



Pressure sensor with display

PF-001BREA12-MFRKG/US//P

Current consumption	[mA]	15...40; (240 at max. load current)
Min. insulation resistance	[MΩ]	100; (500 V DC)
Protection class		III
Reverse polarity protection		yes
Power-on delay time	[s]	0.5
Integrated watchdog		yes

Inputs / outputs

Number of inputs and outputs	Number of digital outputs: 2; Number of analogue outputs: 1
------------------------------	---

Outputs

Total number of outputs		2
Output signal		switching signal; analogue signal; IO-Link; (configurable)
Electrical design		PNP/NPN
Number of digital outputs		2
Output function		normally open / normally closed; (parameterisable)
Max. voltage drop switching output DC	[V]	2
Permanent current rating of switching output DC	[mA]	100
Switching frequency DC	[Hz]	< 170
Number of analogue outputs		1
Analogue current output	[mA]	4...20; (scalable 1:10)
Max. load	[Ω]	500
Analogue voltage output	[V]	0...10; (scalable 1:10)
Min. load resistance	[Ω]	2000
Short-circuit protection		yes
Type of short-circuit protection		pulsed
Overload protection		yes

Measuring/setting range

Measuring range	-50...1000 mbar	-5...100 kPa
Set point SP	-50...1000 mbar	-5...100 kPa
Analogue start point	-50...900 mbar	-5...90 kPa
Analogue end point	50...1000 mbar	5...100 kPa
In steps of	1 mbar	0.1 kPa

Measuring range (kPa)

Factory setting	SSC1.1 SP1 = 25 kPa	SSC1.1 SP2 = 23 kPa
	SSC1.2 SP1 = 75 kPa	SSC1.2 SP2 = 73 kPa
	ASP = 0.00 kPa	AEP = 100 kPa
	dAP = 0.06 s	dAA = 0.06 s

Measuring range (mbar)

Factory setting	SSC1.1 SP1 = 250 mbar	SSC1.1 SP2 = 230 mbar
	SSC1.2 SP1 = 750 mbar	SSC1.2 SP2 = 730 mbar
	ASP = 0.00 bar	AEP = 1000 mbar
	dAP = 0.06 s	dAA = 0.06 s

Accuracy / deviations

Switch point accuracy	< ± 0,5; (DIN EN IEC 62828-1; Turn down 1:1)
-----------------------	--

PF1507



Pressure sensor with display

PF-001BREA12-MFRKG/US//P

	[% of the span]	
Repeatability	[% of the span]	< ± 0,1; (with temperature fluctuations < 10 K; Turn down 1:1)
Characteristics deviation	[% of the span]	< ± 0,5; (DIN IEC EN 62828-1; incl. zero point and span error, non-linearity, hysteresis; Turn down 1:1)
Linearity deviation	[% of the span]	< ± 0,15; (Turn down 1:1)
Zero-point stabilisation	[% of the span]	IO-Link, analogue output 0,25; (see operating instructions zero-point behaviour) display, switching output 0,5
Hysteresis deviation	[% of the span]	< ± 0,15; (Turn down 1:1)
Long-term stability		< ± 0,1; (turn down 1:1; per year)
Temperature coefficient zero point and span	[% of the span / 10 K]	< ± 0,1; (-25...80 °C)
Temperature monitoring		
Accuracy	[K]	± 2 + (0,045 x (Ambient temperature - Medium temperature))
Repeatability	[K]	± 0,2
Response times		
Response time	[ms]	< 3
Damping process value dAP	[s]	0...99.99
Damping for the analogue output dAA	[s]	0...99.99
Step response time analogue output	[ms]	3
Temperature monitoring		
Dynamic response T05 / T09	[s]	< 10 / < 45; (DIN EN 60751 water; > 0,9 m/s)
Software / programming		
Parameter setting options		hysteresis / window; normally open / normally closed; switch-on/ switch-off delay; Damping; Display unit; current/voltage output
Interfaces		
Communication interface		IO-Link
Transmission type		COM3 (230,4 kBaud)
IO-Link revision		1.1
SDCI standard		IEC 61131-9
Profiles	Smart Sensor - SSP 4.1.2	Measuring and Switching Sensor, 2 channel
	Common - I&D	Identification and Diagnosis
	Extension	Quantity detection, switches when value exceeds the setpoint
	Function	Locator
	Function	ProductURI
SIO mode		yes
Required master port type		A
Min. process cycle time	[ms]	1
IO-Link resolution pressure	[mbar]	0.2
IO-Link resolution temperature	[K]	0.2

PF1507



Pressure sensor with display

PF-001BREA12-MFRKG/US//P

IO-Link process data (cyclical)	function	bit length
	pressure	16
	temperature	16
	device status	4
	binary switching information pressure	2
IO-Link functions (acyclical)	binary switching information temperature	
	application specific tag; internal temperature; operating hours counter; switching cycles counter; Pressure peak counter; Temperature peak counter	
Supported DeviceIDs	Type of operation	DeviceID
	default	1975
Note	For further information please see the IODD PDF file under "Downloads"	

Operating conditions		
Ambient temperature	[°C]	-25...80
Storage temperature	[°C]	-40...100
Protection		IP 65; IP 67; IP 69; (to DIN EN 60529)

Tests / approvals		
EMC	DIN EN 61326-1	
Shock resistance	DIN EN 60068-2-27	50 g (11 ms)
Vibration resistance	DIN EN 60068-2-6	10 g (10...2000 Hz)
MTTF	[years]	245
Embedded software included		yes

Mechanical data		
Weight	[g]	192
Housing		cylindrical
Dimensions	[mm]	Ø 34 / L = 117.8
Materials		Housing: stainless steel (316L/1.4404); Operating units: PBT, PC; sealings: FKM; pressure compensation element: PTFE
Materials (wetted parts)		measuring cell: Al ₂ O ₃ (ceramics); Process connection: stainless steel (316L/1.4435) surface characteristics: Ra < 0,4 µm / Rz = 4 µm; Sealing: PTFE; (FKM for sealing with seal DIN EN ISO 1179-2, see operating instructions)
Min. pressure cycles		100 million
Tightening torque	[Nm]	25
Process connection		threaded connection G 1/2 external thread - 21 mm

Displays / operating elements		
Display	Display unit	2x LED, green (bar, kPa)
	switching status	2 x LED, yellow
	measured values	alphanumeric display, red/green 4-digit
Operating elements		3 pushbuttons

Accessories		
Items supplied	Gasket: G1/2, FKM DIN EN ISO1179-2 (-15...80°C), E30492	
Accessories (optional)	Gasket: G1/2, EPDM DIN EN ISO1179-2 (-25...80°C), E30451	
	Gasket: G1/2, FFKM DIN EN ISO1179-2 (-5...80°C), E30513	
	O-ring: 16,4 x 1, FKM (-15...80°C), E30510	
	O-ring: 16,4 x 1, EPDM (-25...80°C), E30511	
	O-ring: 16,4 x 1, FFKM (-5...80°C), E30512	
	cover for filter system: E30605	

PF1507



Pressure sensor with display

PF-001BREA12-MFRKG/US//P

Remarks

Pack quantity 1 pcs.

Electrical connection - plug

Connector: 1 x M12; coding: A; Contacts: 4, gold-plated



Connection

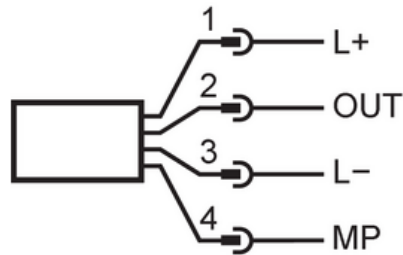

1	L+	
2	OUT	DO2 (NO/NC), AO
3	L-	
4	MP	DO1 (NO/NC), IO-Link