

SICK.COM



DATA SHEET

WTB4SLC-3P2262A00

W4
Photoelectric sensors

SICK Sensor Intelligence

PHOTOELECTRIC SENSORS

WTB4SL-
C-3P2262A00

ORDERING INFORMATION

Type	part no.
WTB4SLC-3P2262A00	1080939

Further device versions and accessories at www.sick.com/W4



Illustration may differ

DETAILED TECHNICAL DATA

FEATURES

Functional principle	Photoelectric proximity sensor						
Functional principle detail	Background suppression						
Sensing range max.	25 mm ... 300 mm ¹⁾						
Sensing range	25 mm ... 300 mm ¹⁾						
Emitted beam	<table border="0"> <tr> <td>Light source</td> <td>Laser ²⁾</td> </tr> <tr> <td>Type of light</td> <td>Visible red light</td> </tr> <tr> <td>Light spot size (distance)</td> <td>Ø 1 mm (170 mm)</td> </tr> </table>	Light source	Laser ²⁾	Type of light	Visible red light	Light spot size (distance)	Ø 1 mm (170 mm)
Light source	Laser ²⁾						
Type of light	Visible red light						
Light spot size (distance)	Ø 1 mm (170 mm)						
Key laser figures	<table border="0"> <tr> <td>Normative reference</td> <td>EN 60825-1:2014, IEC 60825-1:2014 / CDRH 21 CFR 1040.10 & 1040.11</td> </tr> <tr> <td>Laser class</td> <td>1 ³⁾</td> </tr> <tr> <td>Wave length</td> <td>650 nm</td> </tr> </table>	Normative reference	EN 60825-1:2014, IEC 60825-1:2014 / CDRH 21 CFR 1040.10 & 1040.11	Laser class	1 ³⁾	Wave length	650 nm
Normative reference	EN 60825-1:2014, IEC 60825-1:2014 / CDRH 21 CFR 1040.10 & 1040.11						
Laser class	1 ³⁾						
Wave length	650 nm						
Adjustment	Cable, Single teach-in button						
Special applications	Detecting small objects						
Mounting hole	M3						
Pin 2 configuration	External input, Teach-in input, Sender off input, Detection output, logic output						

¹⁾ Object with 90% remission (based on standard white, DIN 5033).

²⁾ Average service life: 50,000 h at T_v = +25 °C.

³⁾ Do not intentionally look into the laser beam. Never point the laser beam at people's eyes.

SAFETY-RELATED PARAMETERS

MTTF _D	326 years (EN ISO 13849-1) ¹⁾
DC _{avg}	0 %
T _M (mission time)	10 years

¹⁾ Mode of calculation: Parts-Count-calculation.

COMMUNICATION INTERFACE

IO-Link	✓, IO-Link V1.1
Data transmission rate	COM2 (38,4 kBaud)
Cycle time	2.3 ms
Process data length	16 Bit
Process data structure	Bit 0 = switching signal Q _{L1} Bit 1 = switching signal Q _{L2} Bit 2 ... 15 = empty
VendorID	26
DeviceID HEX	0x800109
DeviceID DEC	8388873
Compatible master port type	A
SIO mode support	Yes

ELECTRONICS

Supply voltage U _B	10 V DC ... 30 V DC ¹⁾
Ripple	< 5 V _{pp} ²⁾
Current consumption	30 mA ³⁾
Protection class	III
Digital output	Type PNP ⁴⁾ ⁵⁾ Switching mode Light/dark switching ⁴⁾ Output current I _{max.} ≤ 100 mA Response time ≤ 0.5 ms ⁶⁾ Repeatability (response time) 150 μs ⁷⁾ Switching frequency 1,000 Hz ⁸⁾
Output function	Complementary
Circuit protection	A ⁹⁾ B ¹⁰⁾ C ¹¹⁾
Response time Q/ on Pin 2	300 μs ... 450 μs ^{6) 7)}
Switching frequency Q / to pin 2	1,000 Hz ¹²⁾

¹⁾ Limit values when operated in short-circuit protected network: max. 8 A.

²⁾ May not fall below or exceed U_v tolerances.

³⁾ Without load.

⁴⁾ Q = light switching.

⁵⁾ Pin 4: This switching output must not be connected to another output.

⁶⁾ Signal transit time with resistive load.

⁷⁾ Valid for Q \ on Pin2, if configured with software.

⁸⁾ With light/dark ratio 1:1.

⁹⁾ A = V_S connections reverse-polarity protected.

¹⁰⁾ B = inputs and output reverse-polarity protected.

¹¹⁾ C = interference suppression.

¹²⁾ With light / dark ratio 1:1, valid for Q \ on Pin2, if configured with software.

MECHANICS

Housing	Rectangular
Design detail	Slim

PHOTOELECTRIC SENSORS - WTB4SLC-3P2262A00

Dimensions (W x H x D)	12.2 mm x 41.8 mm x 17.3 mm	
Connection	Male connector M8, 4-pin	
Material	Housing	Plastic, Novodur
	Front screen	Plastic, PMMA
Weight	100 g	

AMBIENT DATA

Enclosure rating	IP66 IP67
Ambient operating temperature	-10 °C ... +50 °C
Ambient operating temperature extended	-30 °C ... +55 °C ^{1) 2)}
Ambient temperature, storage	-30 °C ... +70 °C
RoHS certificate	✓

¹⁾ As of T_a = 50 °C, a max. supply voltage V_{max} = 24 V and a max. load current I_{max} = 50 mA is permitted.

²⁾ Operation below Tu -10 °C is possible if the sensor is already switched on at Tu > -10 °C, then cools down, and the supply voltage is subsequently not switched off. Switching on below Tu -10 °C is not permissible.

SMART TASK

Smart Task name	Base logics	
Logic function	Direct AND OR WINDOW Hysteresis	
Timer function	Deactivated Switch-on delay Off delay ON and OFF delay Impulse (one shot)	
Inverter	Yes	
Switching frequency	SIO Direct: 1000 Hz ¹⁾ SIO Logic: 600 Hz ²⁾ IOL: 450 Hz ³⁾	
Response time	SIO Direct: 300 µs ... 450 µs ¹⁾ SIO Logic: 750 µs ... 900 µs ²⁾ IOL: 800 µs ... 1000 µs ³⁾	
Repeatability	SIO Direct: 150 µs ¹⁾ SIO Logic: 150 µs ²⁾ IOL: 400 µs ³⁾	
Switching signal	Switching signal Q _{L1}	Switching output
	Switching signal Q _{L2}	Switching output

¹⁾ SIO Direct: sensor operation in standard I/O mode without IO-Link communication and without using internal sensor logic or time parameters (set to "direct"/"deactivated").

²⁾ SIO Logic: Sensor operation in standard I/O mode without IO-Link communication. Sensor-internal logic or timing parameters plus Automation Functions used.

³⁾ IOL: Sensor operation with full IO-Link communication and usage of logic, timing and Automation Function parameters.

DIAGNOSIS

Device status	Yes
---------------	-----

CERTIFICATES

EU declaration of conformity	✓
UK declaration of conformity	✓
ACMA declaration of conformity	✓
Moroccan declaration of conformity	✓
China RoHS	✓
China Compulsory Product Certification (CCC) exempt	✓
ECOLAB certificate	✓
IO-Link certificate	✓
Laser safety (IEC 60825-1) certificate	✓
Information according to Art. 3 of Data Act (Regulation EU 2023/2854)	✓

CONNECTION DIAGRAM CD-367

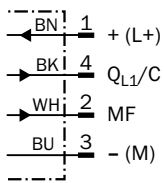

CHARACTERISTIC CURVE

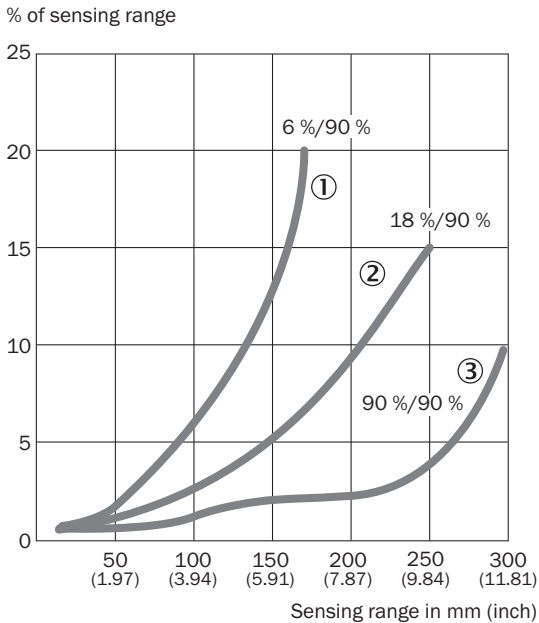

- ① Sensing range on black, 6% remission factor
- ② Sensing range on gray, 18% remission factor
- ③ Sensing range on white, 90% remission factor

LIGHT SPOT SIZE

Radius in mm (inch)

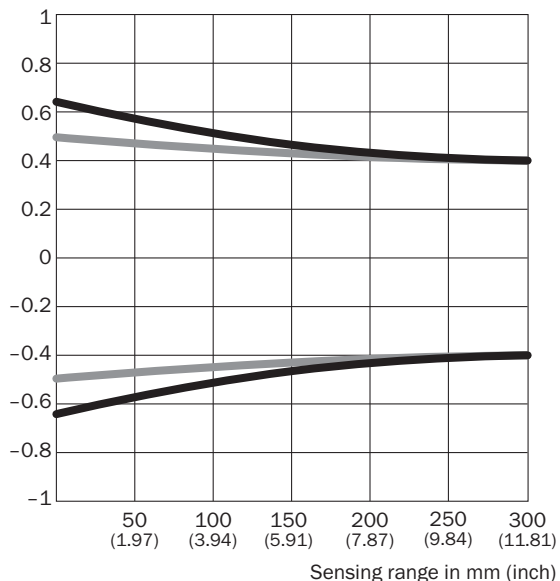

Dimensions in mm (inch)

Sensing range	Vertical	Horizontal
50 mm (1.97)	1.2 (0.05)	1.0 (0.04)
100 mm (3.94)	1.1 (0.04)	1.0 (0.04)
200 mm (7.87)	0.9 (0.04)	0.9 (0.04)
300 mm (11.81)	0.8 (0.03)	0.8 (0.03)

— Vertical
— Horizontal

SENSING RANGE DIAGRAM

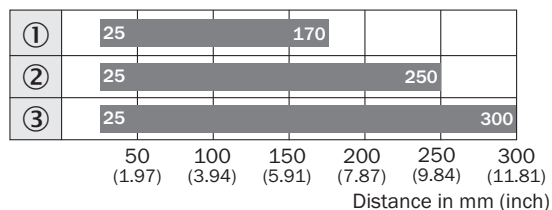

■ Sensing range typ. max.

- ① Sensing range on black, 6% remission factor
- ② Sensing range on gray, 18% remission factor
- ③ Sensing range on white, 90% remission factor

DIMENSIONAL DRAWING

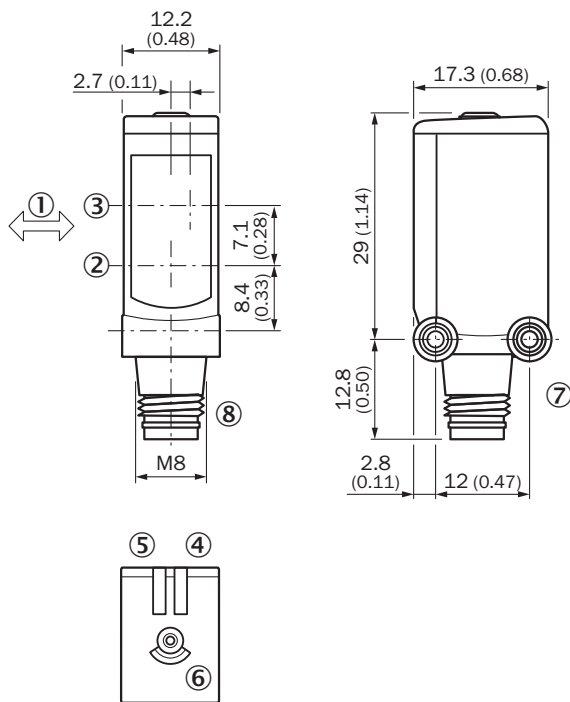

Dimensions in mm (inch)

- ① Standard direction of the material being detected
- ② Center of optical axis, sender
- ③ Center of optical axis, receiver
- ④ LED indicator green: Supply voltage active
- ⑤ LED indicator yellow: Status of received light beam
- ⑥ single teach-in button
- ⑦ Threaded mounting hole M3
- ⑧ Connection

Further information as well as suitable accessories, example applications and downloads such as CAD dimensional models, operating instructions and software can be found at www.sick.com/1080939



SICK AG
WALDKIRCH
GERMANY
SICK.COM

SICK AT A GLANCE

SICK is a leading global technology company for intelligent sensors and integrated solutions in industrial automation. Our technologies set benchmarks, making your industrial processes more efficient, safer and more sustainable – both in logistics and manufacturing operations.

SICK combines sensor intelligence with industry expertise and certified consulting services. We provide the ideal foundation for scalable as well as tailor-made automation solutions and create added value along the entire value chain. Our close partnerships with our customers are more than just a promise: Together, we optimize productivity, improve quality, protect health and safety, and help build a sustainable future. All with empathy and trust.

Since 1946, we have been developing innovative technologies with passion and a pioneering spirit. With a global network in around 40 countries, SICK has a global presence and is always close by. The company's headquarters are located in Waldkirch near Freiburg, Germany. Our customers benefit from our understanding of both local and global requirements, which enables us to deliver tailor-made solutions

SICK
Sensor Intelligence