

SICK.COM



DATA SHEET

WTB4SLC-3P2262A70

W4
Photoelectric sensors

SICK Sensor Intelligence

PHOTOELECTRIC SENSORS

WTB4SL-
C-3P2262A70

ORDERING INFORMATION

| Type | part no. |
|-------------------|----------|
| WTB4SLC-3P2262A70 | 1080940 |

Further device versions and accessories at www.sick.com/W4



Illustration may differ

DETAILED TECHNICAL DATA

FEATURES

| | | | | | | | |
|-----------------------------|---|---------------------|---|---------------|-------------------|----------------------------|-----------------|
| Functional principle | Photoelectric proximity sensor | | | | | | |
| Functional principle detail | Background suppression | | | | | | |
| Sensing range max. | 25 mm ... 300 mm ¹⁾ | | | | | | |
| Sensing range | 25 mm ... 300 mm ¹⁾ | | | | | | |
| Emitted beam | <table border="0"> <tr> <td>Light source</td> <td>Laser ²⁾</td> </tr> <tr> <td>Type of light</td> <td>Visible red light</td> </tr> <tr> <td>Light spot size (distance)</td> <td>Ø 1 mm (170 mm)</td> </tr> </table> | Light source | Laser ²⁾ | Type of light | Visible red light | Light spot size (distance) | Ø 1 mm (170 mm) |
| Light source | Laser ²⁾ | | | | | | |
| Type of light | Visible red light | | | | | | |
| Light spot size (distance) | Ø 1 mm (170 mm) | | | | | | |
| Key laser figures | <table border="0"> <tr> <td>Normative reference</td> <td>EN 60825-1:2014, IEC 60825-1:2014 / CDRH 21 CFR 1040.10 & 1040.11</td> </tr> <tr> <td>Laser class</td> <td>1 ³⁾</td> </tr> <tr> <td>Wave length</td> <td>650 nm</td> </tr> </table> | Normative reference | EN 60825-1:2014, IEC 60825-1:2014 / CDRH 21 CFR 1040.10 & 1040.11 | Laser class | 1 ³⁾ | Wave length | 650 nm |
| Normative reference | EN 60825-1:2014, IEC 60825-1:2014 / CDRH 21 CFR 1040.10 & 1040.11 | | | | | | |
| Laser class | 1 ³⁾ | | | | | | |
| Wave length | 650 nm | | | | | | |
| Adjustment | Cable, Single teach-in button | | | | | | |
| Special applications | Detecting small objects | | | | | | |
| Mounting hole | M3 | | | | | | |
| Pin 2 configuration | External input, Teach-in input, Sender off input, Detection output, logic output | | | | | | |

¹⁾ Object with 90% remission (based on standard white, DIN 5033).

²⁾ Average service life: 50,000 h at T_v = +25 °C.

³⁾ Do not intentionally look into the laser beam. Never point the laser beam at people's eyes.

SAFETY-RELATED PARAMETERS

| | |
|-------------------------------|--|
| MTTF _D | 326 years (EN ISO 13849-1) ¹⁾ |
| DC _{avg} | 0 % |
| T _M (mission time) | 10 years |

¹⁾ Mode of calculation: Parts-Count-calculation.

COMMUNICATION INTERFACE

| | |
|-----------------------------|--|
| IO-Link | ✓, IO-Link V1.1 |
| Data transmission rate | COM2 (38,4 kBaud) |
| Cycle time | 2.3 ms |
| Process data length | 16 Bit |
| Process data structure | Bit 0 = switching signal Q_{L1} Bit 1 = switching signal Q_{L2} Bit 2 ... 15 = measuring value |
| VendorID | 26 |
| DeviceID HEX | 0x80010A |
| DeviceID DEC | 8388874 |
| Compatible master port type | A |
| SIO mode support | Yes |

ELECTRONICS

| | |
|----------------------------------|---|
| Supply voltage U_B | 10 V DC ... 30 V DC ¹⁾ |
| Ripple | < 5 V _{pp} ²⁾ |
| Current consumption | 30 mA ³⁾ |
| Protection class | III |
| Digital output | Type PNP ⁴⁾ ⁵⁾ Switching mode Light/dark switching ⁴⁾ Output current I_{max} ≤ 100 mA Response time ≤ 0.5 ms ⁶⁾ Repeatability (response time) 150 μs ⁷⁾ Switching frequency 1,000 Hz ⁸⁾ |
| Output function | Complementary |
| Circuit protection | A ⁹⁾ B ¹⁰⁾ C ¹¹⁾ |
| Response time Q/ on Pin 2 | 300 μs ... 450 μs ^{6) 7)} |
| Switching frequency Q / to pin 2 | 1,000 Hz ¹²⁾ |

¹⁾ Limit values when operated in short-circuit protected network: max. 8 A.

²⁾ May not fall below or exceed U_V tolerances.

³⁾ Without load.

⁴⁾ Q = light switching.

⁵⁾ Pin 4: This switching output must not be connected to another output.

⁶⁾ Signal transit time with resistive load.

⁷⁾ Valid for Q \ on Pin2, if configured with software.

⁸⁾ With light/dark ratio 1:1.

⁹⁾ A = V_S connections reverse-polarity protected.

¹⁰⁾ B = inputs and output reverse-polarity protected.

¹¹⁾ C = interference suppression.

¹²⁾ With light / dark ratio 1:1, valid for Q \ on Pin2, if configured with software.

MECHANICS

| | |
|---------------|-------------|
| Housing | Rectangular |
| Design detail | Slim |

PHOTOELECTRIC SENSORS - WTB4SLC-3P2262A70

| | | |
|------------------------|-----------------------------|------------------|
| Dimensions (W x H x D) | 12.2 mm x 41.8 mm x 17.3 mm | |
| Connection | Male connector M8, 4-pin | |
| Material | Housing | Plastic, Novodur |
| | Front screen | Plastic, PMMA |
| Weight | 100 g | |

AMBIENT DATA

| | |
|--|------------------------------------|
| Enclosure rating | IP66 IP67 |
| Ambient operating temperature | -10 °C ... +50 °C |
| Ambient operating temperature extended | -30 °C ... +55 °C ^{1) 2)} |
| Ambient temperature, storage | -30 °C ... +70 °C |
| RoHS certificate | ✓ |

¹⁾ As of $T_a = 50\text{ °C}$, a max. supply voltage $V_{max} = 24\text{ V}$ and a max. load current $I_{max} = 50\text{ mA}$ is permitted.

²⁾ Operation below $T_u -10\text{ °C}$ is possible if the sensor is already switched on at $T_u > -10\text{ °C}$, then cools down, and the supply voltage is subsequently not switched off. Switching on below $T_u -10\text{ °C}$ is not permissible.

SMART TASK

| | | |
|--|--|---|
| Smart Task name | Time measurement + debouncing | |
| Logic function | Direct WINDOW | |
| Timer function | Deactivated Switch-on delay Off delay ON and OFF delay Impulse (one shot) | |
| Inverter | Yes | |
| Time measurement accuracy | SIO Direct: --- ¹⁾ SIO Logic: - 0,7 ... + 0,7 ms ± 0,5 % of time measurement value ²⁾ IOL: - 0,9 ... + 0,9 ms ± 0,5% of the time measurement ³⁾ | |
| Time measurement accuracy (e.g. accuracy for time measurement value = 1 s) | SIO Direct: --- SIO Logic: - 5,7 ... + 5,7 ms IOL: - 5,9 ... + 5,9 ms | |
| Resolution time measuring value | 1 ms | |
| Min. Time between two process events (switches) | SIO Direct: --- SIO Logic: 500 µs IOL: 800 µs | |
| Debounce time max. | SIO Direct: --- SIO Logic: 30.000 ms IOL: 30.000 ms | |
| Switching signal | Switching signal Q_{L1} | Output type (dependant on the adjusted threshold) |
| | Switching signal Q_{L2} | Output type (dependant on the adjusted threshold) |
| Measuring value | Time measurement value | |

¹⁾ SIO Direct: sensor operation in standard I/O mode without IO-Link communication and without using internal sensor logic or time parameters (set to "direct"/"deactivated").

²⁾ SIO Logic: Sensor operation in standard I/O mode without IO-Link communication. Sensor-internal logic or timing parameters plus Automation Functions used.

³⁾ IOL: Sensor operation with full IO-Link communication and usage of logic, timing and Automation Function parameters.

DIAGNOSIS

| | |
|---------------|-----|
| Device status | Yes |
|---------------|-----|

CERTIFICATES

| | |
|---|---|
| EU declaration of conformity | ✓ |
| UK declaration of conformity | ✓ |
| ACMA declaration of conformity | ✓ |
| Moroccan declaration of conformity | ✓ |
| China RoHS | ✓ |
| China Compulsory Product Certification (CCC) exempt | ✓ |
| ECOLAB certificate | ✓ |
| IO-Link certificate | ✓ |
| Laser safety (IEC 60825-1) certificate | ✓ |
| Information according to Art. 3 of Data Act (Regulation EU 2023/2854) | ✓ |

CONNECTION DIAGRAM CD-367

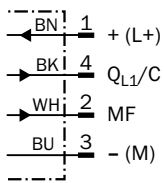

CHARACTERISTIC CURVE

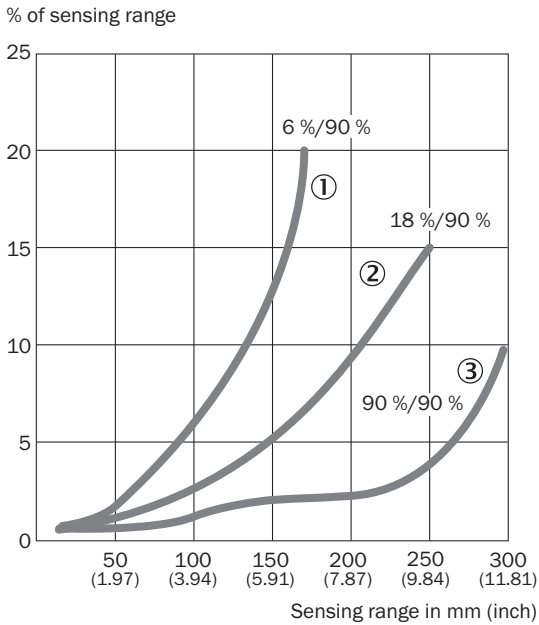

- ① Sensing range on black, 6% remission factor
- ② Sensing range on gray, 18% remission factor
- ③ Sensing range on white, 90% remission factor

LIGHT SPOT SIZE

Radius in mm (inch)

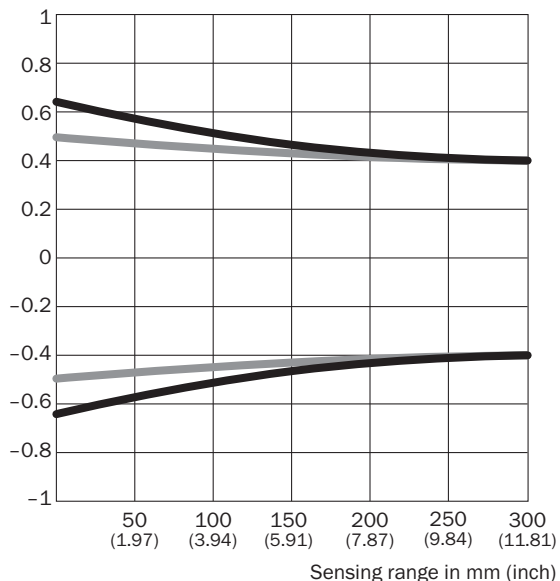

Dimensions in mm (inch)

| Sensing range | Vertical | Horizontal |
|---------------------------------|---------------|---------------|
| 50 mm (1.97) | 1.2 (0.05) | 1.0 (0.04) |
| 100 mm (3.94) | 1.1 (0.04) | 1.0 (0.04) |
| 200 mm (7.87) | 0.9 (0.04) | 0.9 (0.04) |
| 300 mm (11.81) | 0.8 (0.03) | 0.8 (0.03) |

— Vertical
— Horizontal

SENSING RANGE DIAGRAM

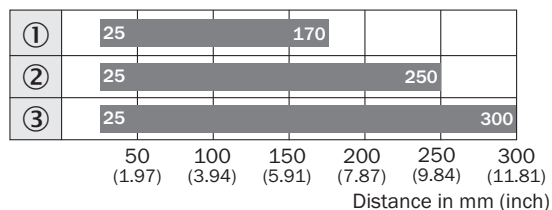

■ Sensing range typ. max.

- ① Sensing range on black, 6% remission factor
- ② Sensing range on gray, 18% remission factor
- ③ Sensing range on white, 90% remission factor

DIMENSIONAL DRAWING

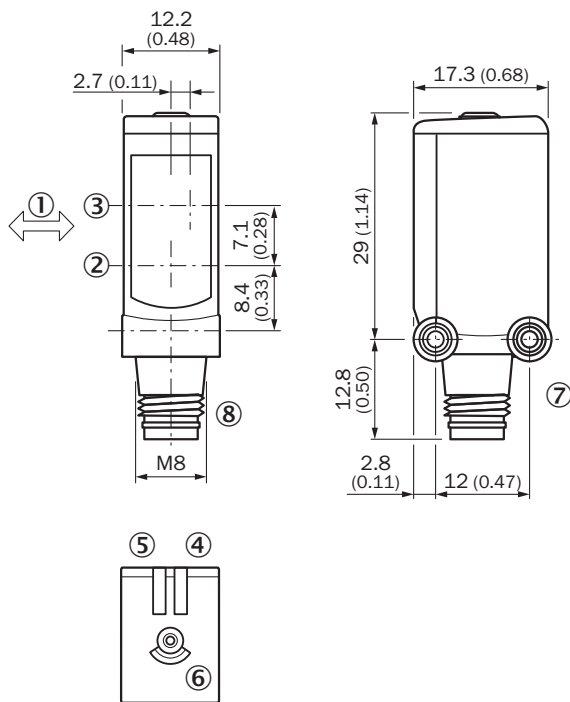

Dimensions in mm (inch)

- ① Standard direction of the material being detected
- ② Center of optical axis, sender
- ③ Center of optical axis, receiver
- ④ LED indicator green: Supply voltage active
- ⑤ LED indicator yellow: Status of received light beam
- ⑥ single teach-in button
- ⑦ Threaded mounting hole M3
- ⑧ Connection

Further information as well as suitable accessories, example applications and downloads such as CAD dimensional models, operating instructions and software can be found at www.sick.com/1080940



SICK AG
WALDKIRCH
GERMANY
SICK.COM

SICK AT A GLANCE

SICK is a leading global technology company for intelligent sensors and integrated solutions in industrial automation. Our technologies set benchmarks, making your industrial processes more efficient, safer and more sustainable – both in logistics and manufacturing operations.

SICK combines sensor intelligence with industry expertise and certified consulting services. We provide the ideal foundation for scalable as well as tailor-made automation solutions and create added value along the entire value chain. Our close partnerships with our customers are more than just a promise: Together, we optimize productivity, improve quality, protect health and safety, and help build a sustainable future. All with empathy and trust.

Since 1946, we have been developing innovative technologies with passion and a pioneering spirit. With a global network in around 40 countries, SICK has a global presence and is always close by. The company's headquarters are located in Waldkirch near Freiburg, Germany. Our customers benefit from our understanding of both local and global requirements, which enables us to deliver tailor-made solutions

SICK
Sensor Intelligence